

ISSN 0934-934 X · K 30285 F

VULKAN-VERLAG

2007

contains
Buyers' Guide

Industrial Valves

International Edition of Industriearmaturen

<http://www.industriearmaturen.de>

High-pressure solenoid valves for gas, hydrogen and other fluids

Jasmin Müller and Dirk Klinksiek
GSR Ventiltechnik GmbH & Co. KG, Vlotho/Germany

published in Industrial Valves, International Edition of Industriearmaturen 2007

Vulkan-Verlag GmbH, Essen, Germany

Contact: W. Mönning, Tel. +49 201 82002-25, w.moening@vulkan-verlag.de

High-pressure solenoid valves for gas, hydrogen and other fluids

By Jasmin Müller and Dirk Klinksiek

This article provides a view of the technology of solenoid valves for high-pressure applications. Their use in natural gas filling stations and for water-mist systems in a fire-fighting system at chemicals giant Bayer are cited as examples.

For more than 35 years, GSR Ventiltechnik has been developing and manufacturing valves for almost all fields of use. Since 1980, the company has been producing valves for high-pressure applications. First, direct operated valves up to nominal diameters of 1/2 inch or 15 mm, for operating pressures of 0 to 180 bar, were developed. Initially, these were used for pump controls in water hydraulic systems.

Valves of this design actuate the sealing element directly via the magnetic system (**Figure 1**). The sealing element, usually a disk, is lifted from its seat by the magnetic force against the effective pressure. The valve is closed via a closing spring with no current flowing.

Direct operated valves operate from 0 bar to the maximum pressure specified; a pressure differential is not necessary. A spring is used to bring valve back to rest.

The sealing materials used depend on the media circulating. Options available are – FKM, NBR, EPDM (ethylene-propylene diene monomers), PTFE (polytetrafluoroethylene) or Tecapeek. The connection sizes range from 1/8 to 1 inch, so that a large number of nominal diameters can be offered. The special characteristic of valves employed for high-pressure applications is their rugged and compact construction. Since they are manufactured from solid metal (such as brass or Type 1.4104 or

1.4571 stainless steel), valves of this kind differ from other solenoid valves. Today, servo-assisted solenoid valves are used increasingly instead of direct operated valves.

Servo-assisted solenoid valves for high-pressure ranges

The valves presented in this article are servo-assisted 2/2-way solenoid valves. They feature a simple, sturdy construction (**Figure 2**).

Valves of this type require a difference in pressure between the valve inlet and outlet to open and close. When the solenoid is energised, the difference in pressure diminishes from the outlet side

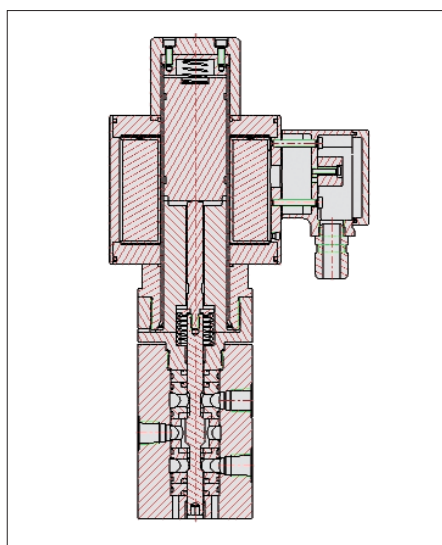

Fig. 1: Type 1313 directly operated slide valve

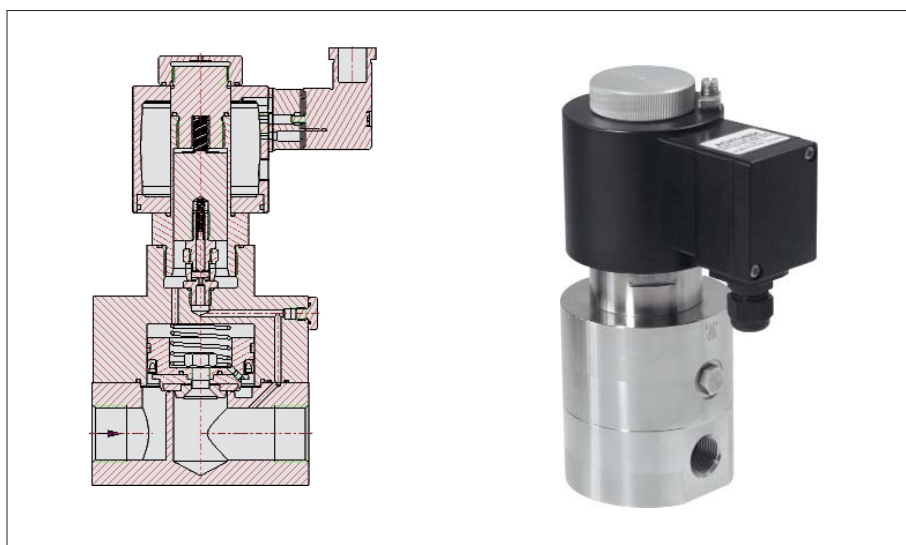

Fig. 2: Type 2529 valve for high pressures up to 450 bar max. 1/8 to 1 G2 connections

of the sealing plunger via the servo port. The effective difference in pressure raises the piston from the valve seat.

The specified minimum pressure differential must always be present for the servo control to work correctly. Here, the solenoid operator merely has a pilot control function, so that the main sealing element is floating. Media pressure differential lifts the main sealing element. If the pressure difference drops below the specified minimum value, the correct operation of the valve is no longer ensured.

As a rule, these valves can be employed everywhere where the medium can expand in the open or in an unpressurized vessel downstream from the valve. These valves are usually not fitted in closed loop circuits.

One advantage of this type of valve is the ability to control high pressures in large nominal bores with low powered solenoids. Since the solenoid coil and the sealing element can be replaced easily if necessary, they are very convenient to service. A wide variety of sealing materials that are matched to the respective medium ensure a long service life of the valves.

Due to increasing environmental awareness and new technologies, customer requirements with respect to solutions for high-pressure applications are becoming more and more specific. The demand for qualified valve technologies in the automotive industry and for fuel-tank facilities has been particularly noticeable. Manufacturers of tank facilities, for example, demand valves that can operate at higher and higher pressures, since filling up a fuel tank at a higher compression also extends the cruising range for a full tank.

Particularly for valves used for natural gas and in hydrogen technology, there are requirements for a high leak-tightness and long service life of the individual components. These demands can be met by improved manufacturing techniques and continuously refined valve geometries, for example, special refinements of the pilot ports and the valve seats. This has made pressure ranges up to 500 bar feasible today.

There is no end to this development in sight, due to constant process alterations.

One of GSR's goals is to offer valves that are suitable for pressures up to 900 bar in future. This goal will soon be achieved, by means of using carefully selected and precisely matched materials, such as special stainless steels.

Expanded applications

Because of the increasing demands from the natural-gas sector and hydrogen field, the possible applications of the valves have been extended constantly. For example, these special valves have been used for the first time in automobile tank facilities.

The valves are undergoing constant improvement. The housings are being optimised all the time, and new materials have been employed. The change of mode of control from direct operated valves to a servo-assisted valve, and a precisely adjusted ratio of the control ports, have made the use of substantially small solenoids possible. Very high c_v values can also be achieved now, by means of an optimised geometry of the valve. Materials matched to the respective medium and operating pressure demonstrate the great flexibility of these types of valve.

In order to minimize friction and extend the service life, the area of the armature guide is specially coated. This in turn prevents the hydrogen media from damaging the valve.

Sample application: Effective fire protection by water-mist technology

The company FOGTEC of Cologne is a specialist in water-mist systems. The company's systems operate with pure water that is atomised at a pressure of 80 to 200 bar. They are not only environment-friendly, but often more effective than conventional gas or water fire-extinguishing systems. With 45 system partners around the world, FOGTEC is the market leader in land-based water-mist systems.

We have chosen the example of the ca-

ble tunnel in Bayer AG's works in Uerdingen to illustrate the functioning of the GSR high-pressure valves in water-mist systems.

At Bayer Uerdingen, the entire underground power-distribution system is fitted with the water-mist technology over a length of six kilometres. Bayer looked for a long time for a fire-protection system that would protect the sensitive cable areas reliably. It was important that this system would not cause any damage to the sensitive materials when triggered, and would not be a danger to the employees, either.

Since the FOGTEC water-mist system works with a very small amount of water, the water residues on the cables and the floor are barely noticeable.

500 special jets, fed by six 120-bar pumps with 21 GSR high-pressure valves now trigger directly in the area concerned when the fire detectors signal an increase in temperature. In this way, the fire is nipped in the bud effectively.

The GSR 2/040 series valves employed here (**Figures 3 and 4**), among others, are 2/2-way servo-assisted solenoid valves. They were designed specifically for fire-extinguishing systems for high pressures (1 to 200 bar). In addition, they can be employed in the entire field of water hydraulic systems.

Conventional sprinkler systems are not suitable for fires that can occur in cable tunnels of the kind described. The large amounts of water that such systems

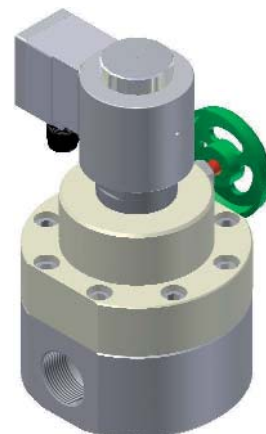

Fig. 3: GSR type 2/040



Fig. 4:
Valve station at
Bayer's Uerdingen
(Krefeld) plant
(source: FOGTEC)

and the choice of materials are decisive.

With the special technology of the RMG system, storing natural gas at high pressures, the solenoid valves are subjected to high frequent switching cycles. The same is required of the solenoid valves when pumping the gas into the vehicles, where pressure differences of 200 bar and more may occur. The resulting stresses make very high demands of the solenoid valves. Since the valves may have maintenance cycles of more than two years, the operating costs of the facility are kept low.

The special features of this high-pressure valve include, besides being designed to the Pressurized Equipment Directive and DIN 3840, certification according to ATEX.

In this valve design, too, only high-quality materials, especially "long life" sealing materials, and high-alloy stainless steels, in part with special coatings, are employed. The valve casings can withstand up to PN 675.

Thanks to their rugged design, these valves can be employed for slightly polluted media without impairment of their functioning. A further advantage is the capability of rapid switching.

The precise matching of the individual components ensures a very long service life of the valve. In addition, the valve is almost maintenance-free over a lengthy

release would cause enormous consequential damage to the electronic components. Furthermore, the relatively large water droplets from the sprinklers fall to the ground quickly, and hardly reach hidden source of fire, such as are typical for wiring fires.

Gas quenching systems, the second traditional fire-extinguishing technology, have no cooling effect, and can only be employed in completely enclosed rooms. Due to the serious hazard to persons from the quenching gas, they require an advanced warning period of at least thirty seconds. These thirty seconds are valuable time that FOGTEC already uses effectively, thus minimizing the fire damage. If the fire detectors signal an increase in temperature, the high-pressure water mist is sprayed immediately, without any delay (**Figure 5**).

The special features of the valve, in particular for this type of application, certainly include its design for a pressure range up to 200 bar for operation with water. The valves are designed in accordance with the Pressurized Equipment Directive and DIN Standard 3840.

The installation of special sealing materials also ensures high stability and leak-tightness, even after lengthy service life. Only high-quality special steels are used for the valve casing and valve internals. The valve is available in the sizes 8 to 50 mm or 1/8 to 2-inch nominal bore, and on request with NPT

threading. A version with flange connections is also possible.

Sample application: Use in natural-gas filling stations

In order to use natural gas as a motor fuel, the natural gas from the pipeline network must be compressed to achieve the desired storage density. The natural gas is compressed to a storage pressure of 250 to 300 bar in filling-station facilities, and then delivered to the natural-gas-powered vehicles.

The stresses and loads occurring in the process make extreme demands on the functioning, leak-tightness, and not least on the safety of the solenoid valves employed (**Figure 6**). For the latter aspect in particular, the quality of manufacture



Fig. 5:
Triggering of the water-mist system in a cable duct (source: FOGTEC)



Fig. 6: Natural-gas filling-station facility featuring GSR high-pressure valves (source: RMG)

period of service. Furthermore, this model of valve is very convenient to install and service. Thanks to their technical design and the sealing materials used, such as Tecapeek or PCTFE, the valves are exceptionally suitable for aggressive media.

Due to its compact construction, it is possible to use this valve in a valve assembly, as well. At present, three position and six position valve assemblies have been implemented in natural-gas filling stations (**Figure 7**). Non-return valves, filters, and adjustable overflow

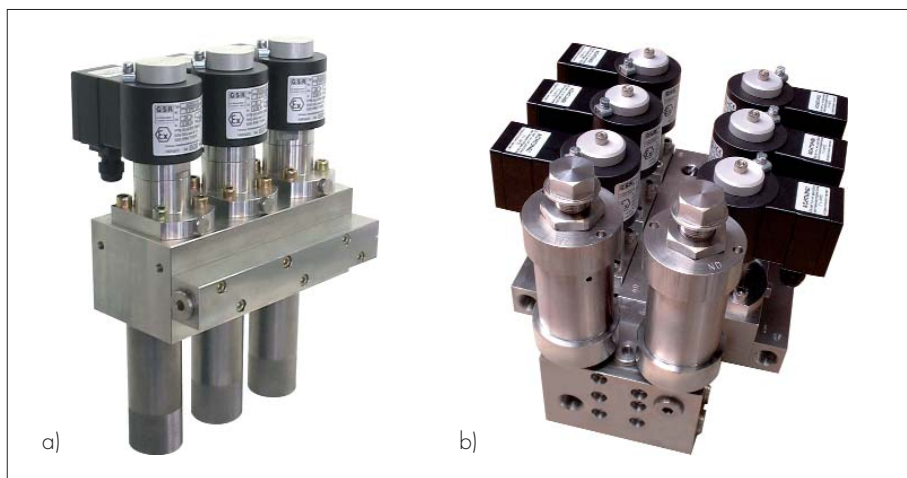

Fig. 7: (a) Triple valve assembly with integrated filters, (b) six-valve assembly

valves can be integrated in the assemblies.

In a special version, this valve is suitable for high-temperature applications. In this case, the parameters concerned must be adjusted accordingly.

Due to the connection sizes, ranging from 6 to 25 mm nominal bore, which are also available in spigot- and socket models from 1/8 to 1 inch nominal bore or with NPT threading, this valve can be supplied to the customer's requirements. The angle-valve version offers high flexibility, because the connections can be arranged as desired. This valve is available optionally in a flange-mounted version. Depending on the application, the high-pressure valve can be supplied with a large number of options.

In general, the valves that are designed for these particularly high pressures can also be employed for hydrogen. In order to meet the specific market demands in this field, GSR Ventiltechnik is constantly developing new high-quality valve solutions.



Jasmin Müller
GSR Ventiltechnik
GmbH & Co. KG,
Vlotho/Germany
Phone: +49-5228-779-356
jmueller@ventiltechnik.de



Dirk Klinksiek
GSR Ventiltechnik
GmbH & Co. KG,
Vlotho/Germany
Phone: +49-5228-779-327
dklinksiek@ventiltechnik.de