



Technical Data Sheet Type 2/164FL



Type 2/164FL

2/2-way solenoid valve
 NC - Valve normally closed (as standard)
 NO - Valve normally open (as option)

Force-pilot operated piston design valve. No differential pressure is necessary for operation. In standard (NC) the valve closes with spring power.

■ Solenoid valve for extended temperature range

TECHNICAL SPECIFICATIONS

Type of control	Force-pilot operated
Design	Piston design
Connection	Flange DN15 - DN100 EN 1092-1 Form B1/B2
Installation	Actuator downwards
Pressure	0 - 40 bar (see table on page 2)
Medium	Clean, neutral, gaseous and liquid media
max. viscosity	22 mm ² /s
Temperature range	Medium: -40 °C up to +300 °C Ambient: -40 °C up to +50 °C <small>In consideration of the restrictions described on page 4</small>
Body material	Cast steel GP240 GH Stainless steel 1.4581
Metallic inner parts	Stainless steel
Sealing	Metallic
Supply voltage	AC~ 24V, 110V, 230V <small>via external rectifier (included in delivery)</small> DC= 12V, 24V <small>Other supply voltages on request</small>
Voltage tolerance	-10% / +10%
Power consumption	T242 = 26 Watt T272 = 60 Watt T352 = 80 Watt
Protection class	IP65 acc. to DIN 60529
Duty factor	100% ED-VDE 0580
Connection type	Terminal box

VALVE FEATURES

- For media temperatures up to +300 °C
- No pressure difference is required
- High life time
- High-quality materials
- Reliable and sturdy sealing elements

FUNCTION

NC – non energized closed

NO – non-energized open

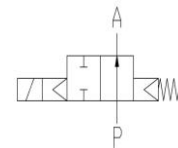
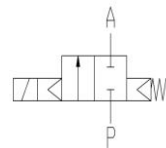

CERTIFICATES



ORDERING SYSTEM

Type	Connect.	Housing	Seal	Coil	Option
2 / 1 6 4	- 0 3	- 0 8	0 0	- T 2 7 2	- D T
	01 DN15 02 DN20 03 DN25 04 DN32 05 DN40 06 DN50 07 DN65 08 DN80 09 DN100	05 GP240 GH 08 St. steel 1.4581	00 metall.	T Temperature design	DT +300 °C

TECHNICAL FEATURES

DN	Kv-value m ³ /h	Standard type	max. pressure for coils		
			T242-DT	T272-DT	T352-DT
15	5,0	2/164-01-..00-	0-25	-	-
20	11,0	2/164-02-..00-	0-16	0-40	-
25	13,0	2/164-03-..00-	0-16	0-40	-
32	28,0	2/164-04-..00-	-	0-25	0-40
40	30,0	2/164-05-..00-	-	0-25	0-40
50	46,0	2/164-06-..00-	-	0-25	0-40
65	75,0	2/164-07-..00-	-	0-12	0-20
80	97,0	2/164-08-..00-	-	-	0-16
100	143,0	2/164-09-..00-	-	-	0-5

The flow rate mentioned in the table applies to the strongest coil.

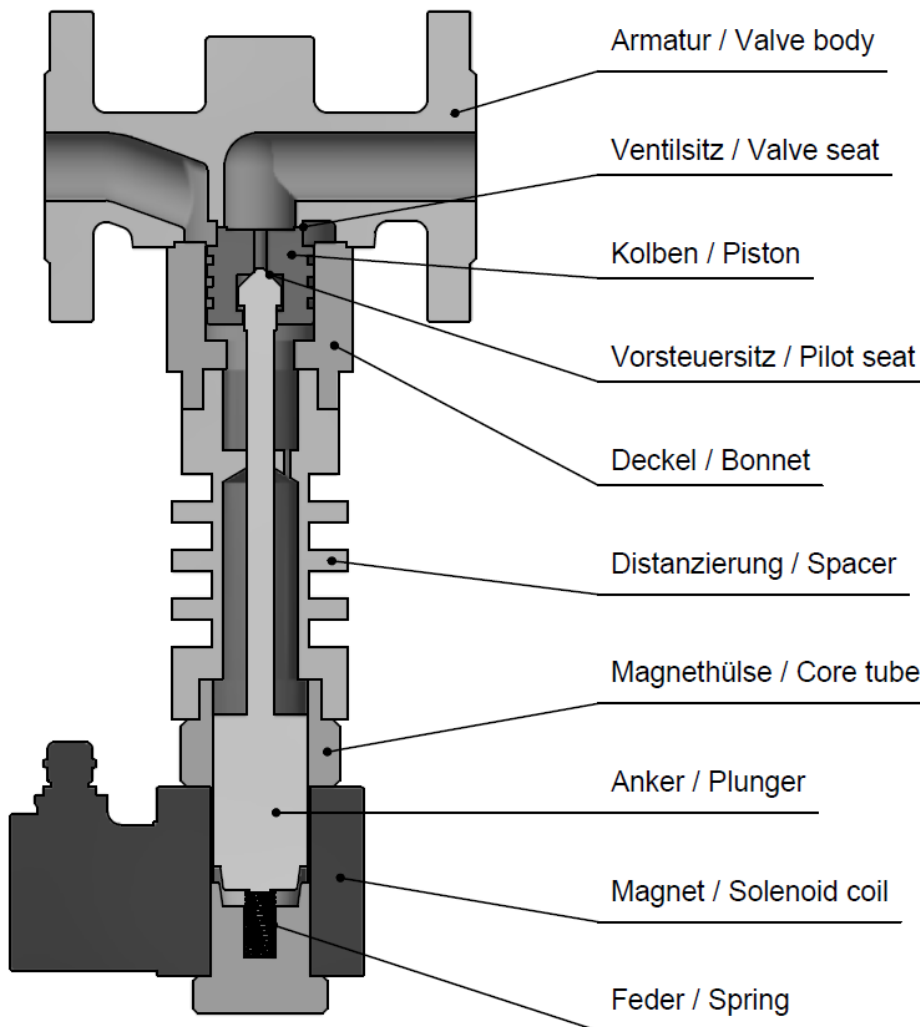

DIMENSIONS

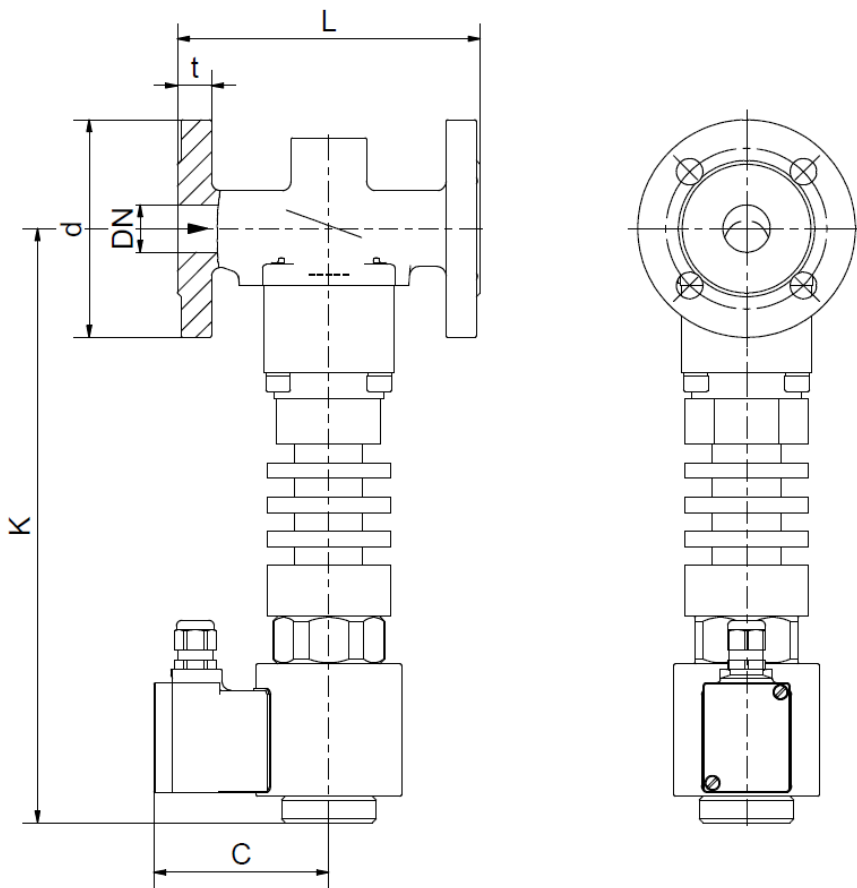

Coil	T242			T272					
Type	2/164-01	2/164-02	2/164-03	2/164-02	2/164-03	2/164-04	2/164-05	2/164-06	2/164-07
DN	15	20	25	20	25	32	40	50	65
C	93	93	93	107	107	107	107	107	107
d	95	105	115	105	115	140	150	165	185
K	285	315	315	335	335	355	355	361	395
L	130	150	160	150	160	180	200	230	290
t	16	18	18	18	18	18	18	20	22
kg	6,7	10,0	10,6	14,2	14,7	18,1	18,1	20,0	32,4

Coil	T352					
Type	2/164-04	2/164-05	2/164-06	2/164-07	2/164-08	2/164-09
DN	32	40	50	65	80	100
C	127	127	127	127	127	127
d	140	150	165	185	200	235
K	430	430	415	461	476	491
L	180	200	230	290	310	350
t	18	18	20	22	24	24
kg	31,0	31,0	32,5	45,5	58,0	68,0

INFORMATION

- It is imperative to observe the installation and safety instructions in our operating and service manuals.
- For information on our GSR ordering code, please refer to our catalogs. If you have any questions, we will be glad to assist you.
- Required ordering information: valve type, function NC/NO, pressure range, connection, nominal width, medium, flow rate, medium and ambient temperatures, connection voltage.
- **Detailed production-specific drawings and other technical information will be made available when an order is placed**

PLEASE NOTE

Each individual application decides which valve type is required, the main factor being the resistance of the materials to the operating medium. The correct selection of materials requires knowledge of the concentration, temperature and degree of contamination of the medium. Other criteria include the operating pressure and max. volumetric flow, since, in addition to high temperatures, high pressures and high flow rates must also be taken into account when selecting the materials.

All materials used for our valves, be it housing, seals or magnets, will be carefully selected in view of the different application areas. Any information given is non-binding and serves for orientation only. No claims under warranty can be derived therefrom.

Heating and power of solenoid coils

The GSR default solenoid valves are designed for continuous operation (100% ED = power-on time) under normal operating conditions. The pulling force of a solenoid coil is basically influenced by three elements:

- The self-heating of the magnetic coil
- The medium temperature
- The ambient temperature

GSR solenoid coils are by default designed for a maximum ambient temperature of +35 °C. This specification applies for the maximum allowable operating pressure specified in the data sheet of the corresponding valve, 100% duty cycle and a medium temperature of +300 °C.

A higher ambient temperature is possible, when lower values are applied for the other influencing parameters. When the max. operation pressure and max. ambient temperature of +50 °C is given the medium temperature is not allowed to be higher than max. +270 °C. In addition to that, deviations from the default design temperature range are possible, e.g. when temperature coils or other constructive measures are used. Please contact the GSR headquarters to discuss the specific application.

More precise specifications and technical data with regard to the operating conditions can be found in the data sheets of the solenoid coils and the solenoid valve regarded. Please observe that the surface temperature of a permanently loaded coil can amount up to +120 °C, solely by the self-heating of the coil. The power consumption of our default solenoid valves was calculated to DIN VDE 05820 for a coil temperature of +20 °C.

- The GSR logo is a registered trademark of GSR Ventiltechnik GmbH & Co. KG.
- Note: All texts and images are the property of GSR Ventiltechnik GmbH & Co. KG and must not be replicated or modified, not even in part, without written approval.
- Original products may differ from the product images shown, due to different materials and the like.
- Subject to error and changes.

Stand: 09.17, MK-MG, Version 1.