



Technical Data Sheet Type 2/049



2/2-way solenoid valve
 NC - Valve normally closed (as standard)
 NO - Valve normally open (as option)

Force-pilot operated piston design valve. No differential pressure is necessary for operation. In standard (NC) the valve closes with spring power.

■ Solenoid valve for higher viscosity applications

Type 2/049

TECHNICAL SPECIFICATIONS

Type of control	Force pilot operated no pressure difference required
Design	Piston design
Connection	Flanges DN50 - DN100 EN 1092-1 Form B1/B2 Other flange connections like ASME on request
Installation	With actuator upright
Pressure	0 - 40 bar (see table on page 2)
Medium	Clean, neutral, gaseous and liquid media
max. viscosity	150 mm ² /s
Temperature range	Medium: -30 °C up to +80 °C Ambient: -30 °C up to +50 °C In consideration of the restrictions described on page 4
Body material	Cast iron EN-GJL-250 Cast steel GP240 GH
Metallic inner parts	Brass and Stainless steel
Sealing	PTFE
Supply voltage	AC~ 24V, 110V, 230V DC= 12V, 24V Other supply voltages on request
Voltage tolerance	-10% / +10%
Power consumption	.242 = 46 Watt .248 = 30 Watt .272 = 100 Watt .278 = 47 Watt .352 = 150 Watt .358 = 75 Watt
Protection class	IP65 acc. to DIN 60529
Duty factor	100% ED-VDE 0580
Connection type	Terminal box
Ex-proof	acc. to 2014/34/EU (ATEX) Further Ex-proof on request

VALVE FEATURES

- For media viscosity up to 150 mm²/s
- No pressure difference is required
- High life time
- High-quality materials
- Reliable and sturdy sealing elements

FUNCTION

NC – non energized closed

NO – non-energized open

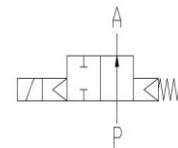
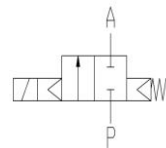

CERTIFICATES



ORDERING SYSTEM

Type	Connect.	Housing	Seal	Coil
2 / 0 4 9	- 0 9	- 0 5	0 4	- . 3 5 2
	06 DN50 07 DN65 08 DN80 09 DN100	04 EN-GJL-250 05 GP240 GH	04 PTFE	2 Standard IP65 8 Explosion proof acc. to directive 2014/34/EU (ATEX)

TECHNICAL FEATURES

DN	Kv-value m ³ /h	Standard type	max. pressure for coils			max. pressure for coils ATEX		
			.242	.272	.352.	.248	.278	.358
50	46,0	2/049-06-..04-	-	0-25	0-40	on request		
65	75,0	2/049-07-..04-	0-6	0-25	0-40			
80	97,0	2/049-08-..04-	-	0-10	0-40			
100	143,0	2/049-09-..04-	-	-	0-40			

The flow rate mentioned in the table applies to the strongest coil.
 Max. Druckbereich 16 bar bei EN-GJL-250 Armatur PN16

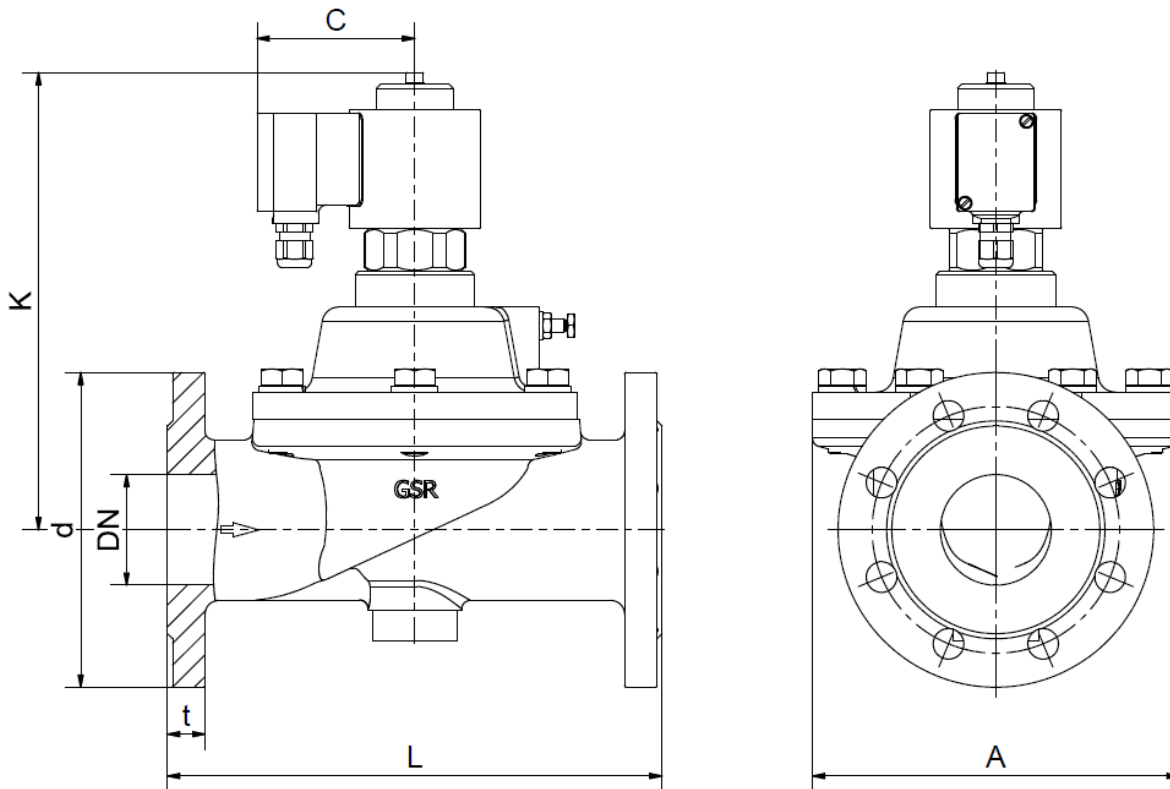

Coil	.242/.248		.272/.278		.352/.358			
Type	.2407	.2406	.2407	.2408	.2406	.2407	.2408	.2409
DN	65	50	65	80	50	65	80	100
A	215	112	215	245	112	215	245	270
C	93	107	107	107	127	127	127	127
d	185	165	185	200	165	185	200	235
K	270	252	295	295	on req.	380	390	380
L	290	230	290	310	230	290	310	350
t	22	18	22	24	18	22	24	24
kg	27,0	on req.	30,5	38,5	on req.	43,0	50,0	61,0

INFORMATION

- It is imperative to observe the installation and safety instructions in our operating and service manuals.
- For information on our GSR ordering code, please refer to our catalogs. If you have any questions, we will be glad to assist you.
- Required ordering information: valve type, function NC/NO, pressure range, connection, nominal width, medium, flow rate, medium and ambient temperatures, connection voltage.
- **Detailed production-specific drawings and other technical information will be made available when an order is placed**

PLEASE NOTE

Each individual application decides which valve type is required, the main factor being the resistance of the materials to the operating medium. The correct selection of materials requires knowledge of the concentration, temperature and degree of contamination of the medium. Other criteria include the operating pressure and max. volumetric flow, since, in addition to high temperatures, high pressures and high flow rates must also be taken into account when selecting the materials.

All materials used for our valves, be it housing, seals or magnets, will be carefully selected in view of the different application areas. Any information given is non-binding and serves for orientation only. No claims under warranty can be derived therefrom.

Heating and power of solenoid coils

The GSR default solenoid valves are designed for continuous operation (100% ED = power-on time) under normal operating conditions. The pulling force of a solenoid coil is basically influenced by three elements:

- The self-heating of the magnetic coil
- The medium temperature
- The ambient temperature

GSR solenoid coils are by default designed for a maximum ambient temperature of +35 °C. This specification applies for the maximum allowable operating pressure specified in the data sheet of the corresponding valve, 100% duty cycle and a medium temperature of +80 °C.

A higher ambient temperature is possible, when lower values are applied for the other influencing parameters. When the max. operation pressure and max. ambient temperature of +50 °C is given the medium temperature is not allowed to be higher than max. +50 °C. In addition to that, deviations from the default design temperature range are possible, e.g. when temperature coils or other constructive measures are used. Please contact the GSR headquarters to discuss the specific application.

More precise specifications and technical data with regard to the operating conditions can be found in the data sheets of the solenoid coils and the solenoid valve regarded. Please observe that the surface temperature of a permanently loaded coil can amount up to +120 °C, solely by the self-heating of the coil. The power consumption of our default solenoid valves was calculated to DIN VDE 05820 for a coil temperature of +20 °C.

- The GSR logo is a registered trademark of GSR Ventiltechnik GmbH & Co. KG.
- Note: All texts and images are the property of GSR Ventiltechnik GmbH & Co. KG and must not be replicated or modified, not even in part, without written approval.
- Original products may differ from the product images shown, due to different materials and the like.
- Subject to error and changes.

Stand: 12.17, MK-MG, Version 1.